

COUNTPACK

AUTOMATIC COUNTING AND PACKAGING SYSTEM FOR BREAD ROLLS

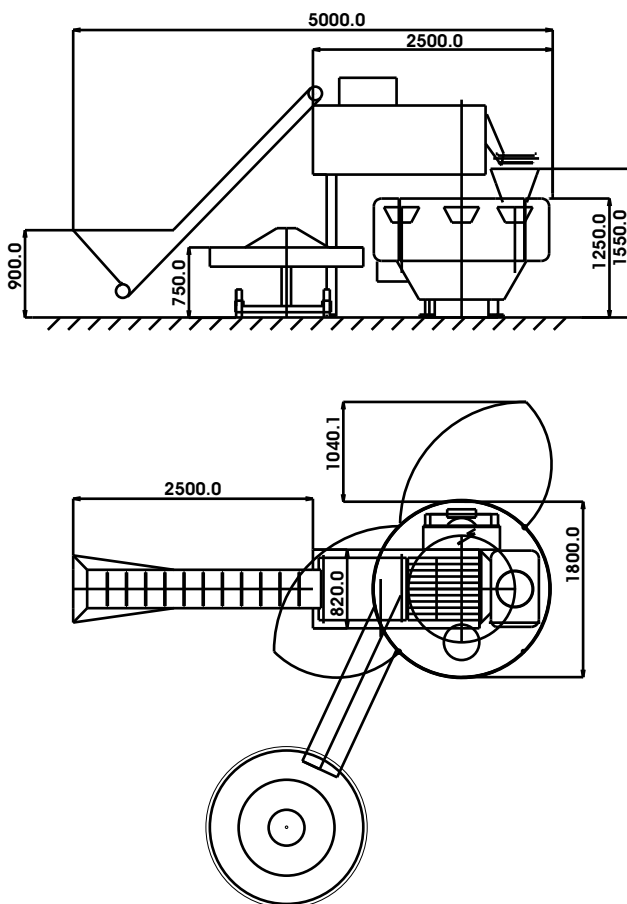

CountPack system is solution for counting and packaging of bread rolls and corresponding products. The system consists of a Counter5 - counting station and CarouselPack- bagging and clip-closing station. An elevator conveyor with product hopper, a bag conveyor and a rotating collecting table are normally included in a total installation. A hot stamping unit for 'best before'-dating onto the clip-band is available as an option.

The product infeed can be arranged either from the baking plates to the product hopper or direct from the cooling conveyor to this buffer hopper. Compartment conveyor guides the products to the counting station situated on top of the machine. For maximised utilisation of the floor area the infeed and outlet conveyors can be placed even at the sides of the machine.

The mechanically driven vibrator troughs are steplessly adjustable for desired capacity. A brush unit ensures that only one product layer moves to the counting station. The multilevel vibrating troughs ensure perfect separation of the products before counting.

The counting station consists of high sensitive optical sensors and PLC- steered gate units. The standard version is equipped with five vibrator troughs and photocells giving a counting speed of approx. 15 000 units/hour. The amount per portion is easily selectable.

The CarouselPack- bagging station consists of four circulating filling hoppers with integrated bag holders. With the bags hanging from the hoppers, they circulate from the bag opening station to the filling station and further to the bag closing and discharge station. Simultaneous operations at different machine stations enable high packaging capacity with well-controlled calm functions. The bagging capacity of some 25 -28 bags/minute can be reached depending on the product and size of the portion.

The change of the bag bunches and size is easy and rapid. The unique bag opening and holding system is realised with extremely reliable mechanical solution. The clip-closing unit is the result of more than 20 years of experience and already 600 units delivered.

The IPEKA-counting units and CarouselPack- bagging units are also available separately. Counting units with 8-10 counting troughs has been installed for example to box packaging stations and high-speed FFS-packaging machines for frozen rolls, buns and pies.

IPEKA



Ipeka Automation Oy
Palokuja 1
37800 Toijala
FINLAND

Tel. +358 3 275 2200
Fax +358 3 275 2222
www.ipeka.com
mail@ipeka.com